

AC POWERED HYDRAULIC SCISSOR LIFT TABLE - SCTAB-2000-3240-AC

APPROX WEIGHT: 357.86 lbs. DOES NOT INCLUDE WEIGHT OF POWER OR PACKAGING!!!

*** ANY ADDITIONS, DELETIONS, OR OMISSIONS MUST BE CORRECTED ON THIS DRAWING AS THIS DRAWING WILL BE CONSIDERED ALL INCLUSIVE ***
 ALL GRAPHICS PROVIDED ARE FOR REFERENCE ONLY. IF CERTAIN DIMENSIONS ARE CRITICAL PLEASE VERIFY THOSE DIMENSIONS WITH YOUR SALESPERSON

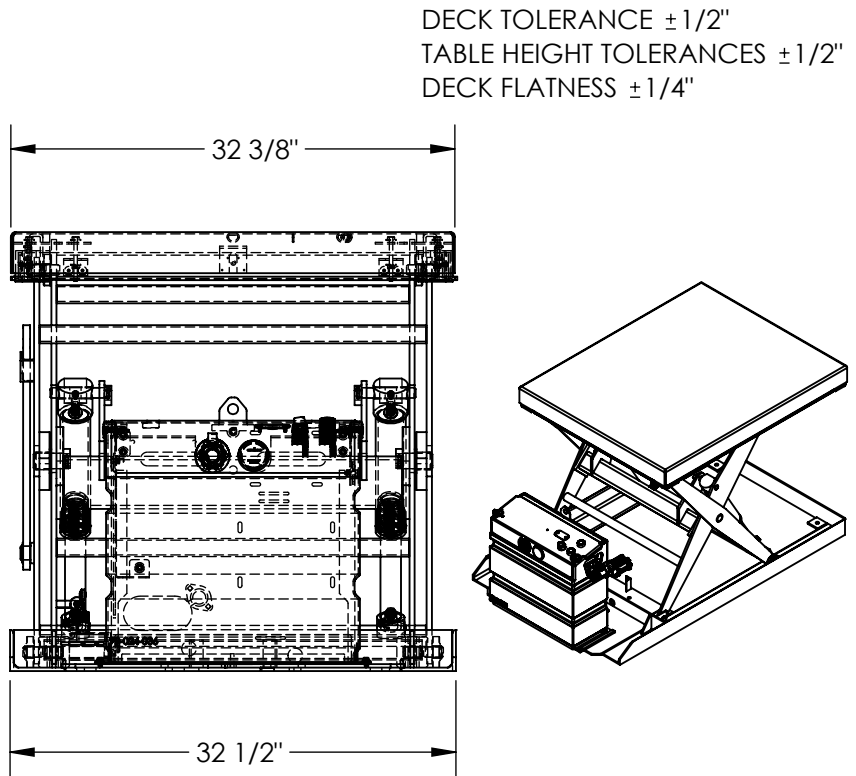
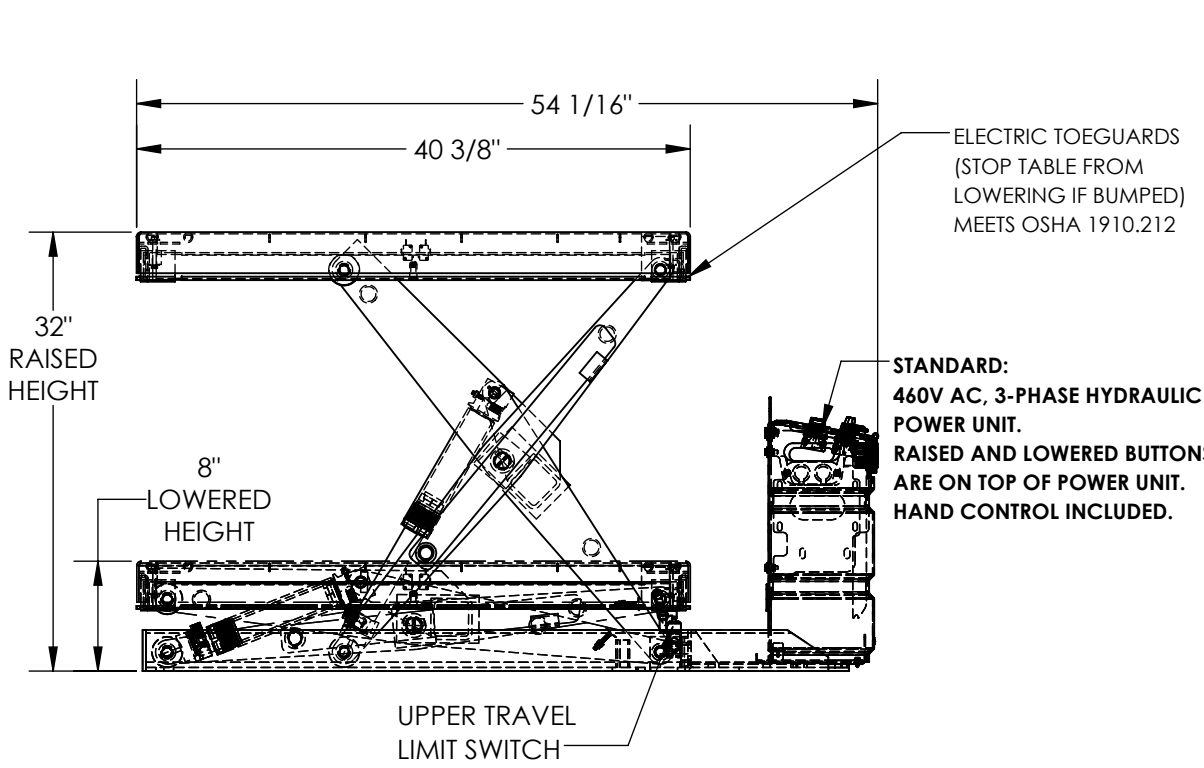

STANDARD FEATURES

- MODEL NUMBER IS SCTAB-2000-3240-AC
- DECK WIDTH IS 32 3/8"
- DECK LENGTH IS 40 3/8"
- RAISED HEIGHT IS 32"
- LOWERED HEIGHT IS 8"
- TABLE CAPACITY (EVENLY DISTRIBUTED) MAX CAPACITY IS 2,000 LBS
- CONTROL IS HANDHELD 2 BUTTON, NEMA 4 PENDANT WITH MINIMUM 8' USABLE COIL CORD
- SAFETY MAINTENANCE PROPS, DISPLACEMENT STYLE CYLINDERS INSTALLED ROD DOWN
- EMERGENCY SAFETY STOP HYDRAULIC FUSES
- UPPER TRAVEL LIMIT SWITCH
- ELECTRIC PINCH POINT GUARD
- DURABLE LIQUID PAINT BLUE FINISH

SPECIAL FEATURES

NONE

PLEASE CIRCLE SPECIFICATIONS:

POWER	AC	DC (12V)	AIR/OIL
MOTOR VOLTAGE	115	208	230 460
DEDICATED CIRCUIT REQUIRED 60Hz			
MOTOR PHASE	SINGLE	THREE	
CONTROL	HAND	FOOT	

DIMENSION TOLERANCE ± 1/4"

APPROVAL

I, THE UNDERSIGNED, AGREE THAT THE PRODUCT AS REPRESENTED SATISFIES DESIGN AND DIMENSION REQUIREMENTS. I ALSO ACKNOWLEDGE MY DUTY TO CONFIRM PRODUCT AND INSTALLATION COMPLIANCE WITH ALL APPLICABLE FEDERAL, STATE AND LOCAL REGULATIONS AND STANDARDS.

ANY MODIFIED UNITS ARE NON-RETURNABLE

[] As drawn [] As marked

Signed: _____ Date: _____

Printed Name: _____

LEAD TIME WILL START UPON RECEIPT OF SIGNED APPROVAL DRAWING

FOR INTERNAL USE ONLY PROJECT SIGN OFF

SALES	
ENG.	
FAB.	
POWER	

DISTRIBUTOR'S NAME:		P.O.#
VESTIL MANUFACTURING		X
DRAWN BY: CRA	DATE: 06/03/2019	W.O.#
REFERENCE: X	SCALE: 1:14	X
QUOTED LEAD TIME: X	QUOTE #	FILE NAME:
	X	01-007-397